

# PITELMEC

## *Thumper 240S* DOWN THE HOLE HAMMER



THUMPER 240S FOR HOLE DIAMETER 800 - 1000MM

# PNEUMEC THUMPER 240S 24" DOWN THE HOLE HAMMER

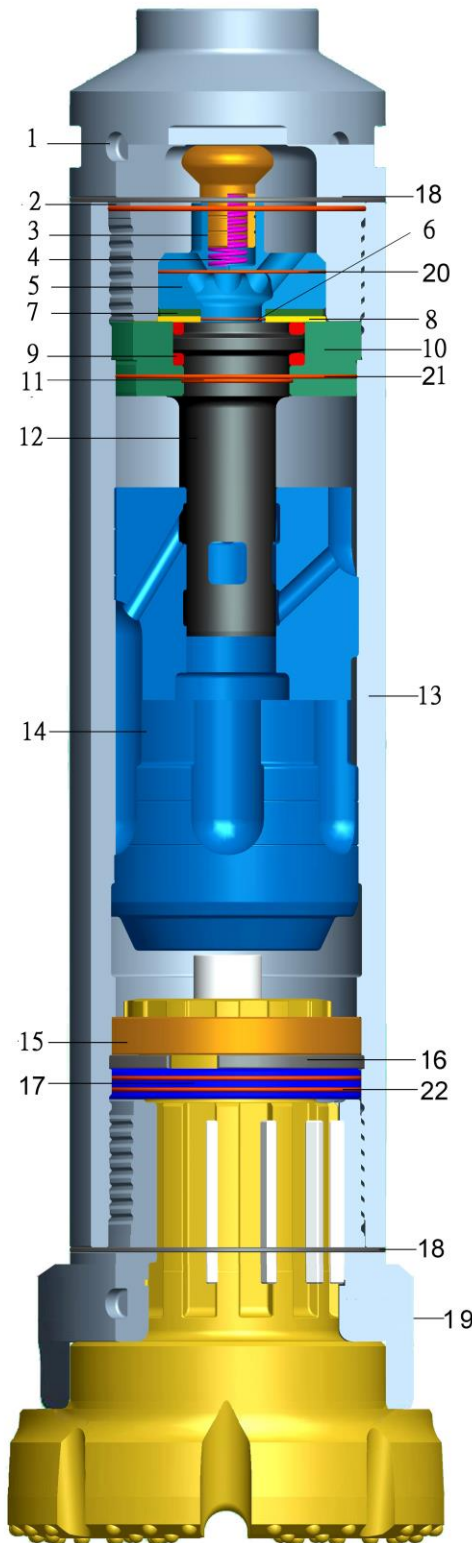

## THUMPER 240S HAMMER PARTS LIST

1.	BACKHEAD 8-5/8" API REG BOX	HSP24S1T6F
2.	BACKHEAD "O" RING	HSP24S2
3.	CHECKVALVE	HSP24S3
4.	CHECK VALVE SPRING	HSP24S4
5.	VALVE CHEST	HSP24S5
6.	MAKE UP PLATE "O" RING	HSP24S6
7.	MAKE UP RING	HSP24S22
8.	MAKE UP PLATE	HSP24S23
9.	CONTROL TUBE RING (2)	HSP24S10
10.	CONTROL TUBE HOLDER	HSP24S7
11.	TUBE HOLDER SEAL	HSP24S20
12.	CONTROL TUBE	HSP24S8
13.	WEARSLEEVE	HSP24S18
14.	PISTON	HSP24S12N24
15.	GUIDE BUSH	HSP24S26
16.	PISTON RING	HSP24S25
17.	BIT RETAINERS	HSP24S15N24
18.	WASHER (2)	HSP24S21
19.	CHUCK P240S	HSP24S1924S
20.	VALVE CHEST SEAL	HSP24S5S
21.	CONTROL TUBE HOLDER "O" RING	HSP24S20A
22.	BIT RETAINER "O" RING	HSP24S16
23.	COMPLETE HAMMER 240S	HAM24S24STHP

## THUMPER 240S HAMMER SPECIFICATIONS

DIAMETER	520MM
LENGTH	2300MM
PISTON WEIGHT	600KG
HAMMER WEIGHT	2,600KG
HOLE DIAMETER	800MM – 1100MM
STROKE	152MM
BACKHEAD CONNECTION : STANDARD	8-5/8" API REG BOX
OPTIONAL	HEX120L
SHANK TYPE	P240S

## THUMPER 240S HAMMER AIR CONSUMPTION

PRESSURE (BAR / PSI)	CFM	M <sup>3</sup> /MIN
6.9 / 100	2188	62
10.3 / 150	4024	114
13.8 / 200	6190	175
15.2 / 225	7386	209

# PNEUMEC

**PNEUMEC COMPANY LIMITED**

1st Floor, Tin On Sing Comm. Bldg., 41-43 Graham St. Central, H.K.

Tel : (852) 2180 9922

Fax : (852) 2180 9982

Website : [www.pneumec.com](http://www.pneumec.com)

email : [info@pneumec.com](mailto:info@pneumec.com)